

E12B23LWBL00

AC axial fans

> CONTACT US



An EC fan (stand for Electronically Commutated) is a brushless, direct current, motor. This runs on a DC voltage, but with a single phase AC supply. Thanks an electronic PCB board included in the stator, single phase AC voltage is transformed into a direct voltage by an AC/DC converter. EC motors assure energy efficiency, quiet operation and high performances.

Technical data		
APPROVALS		
Approvals	CE; UKCA	
PERFORMANCE		
Max Airflow	104/104 61/61	m³/h CFM
Max Static Pressure	20/20 0.08/0.08	Pa in H2O
RPM	1600/1600	RPM
ELECTRICAL DATA		
Rated Voltage	230	V a.c.
Rated Current	0.03/0.03	A
Rated Power	1.7/1.7	W
Operating Voltage	140-264	V a.c.
Frequency	50/60	Hz
Appliance Class	II	
Motor Protection	Impedance Protected	
MECHANICAL DATA		
Bearing	Ball Bearing	
GENERIC DATA		
Casing Material	Plastic UL94-V0	
Life Expectancy	70000	h at 40 °C
	70000	h at 104 °F

Image is for illustrative purpose only. All specifications, data and drawing are subject to change without notice. Please refer to our terms of sales including our warranty and limited liabilities clauses.

Technical data		
Airflow Direction	Air exhaust over brackets	
Electrical Connection	Wires	
Fan Noise	27.5/27.5	dB(A)
Cable Length	1500	mm
	59.06	in
Fixing System	Screws	
ENVIRONMENTAL AND THERMAL DATA		
IP Protection Degree	IP20	
Operating Temperature	-30÷70	°C
	-22÷158	°F
Storage Temperature	-40÷75	°C
	-40÷167	°F

Image is for illustrative purpose only. All specifications, data and drawing are subject to change without notice. Please refer to our terms of sales including our warranty and limited liabilities clauses.

E12B23LWBL00

AC axial fans

> CONTACT US

Technical drawing mm (in)

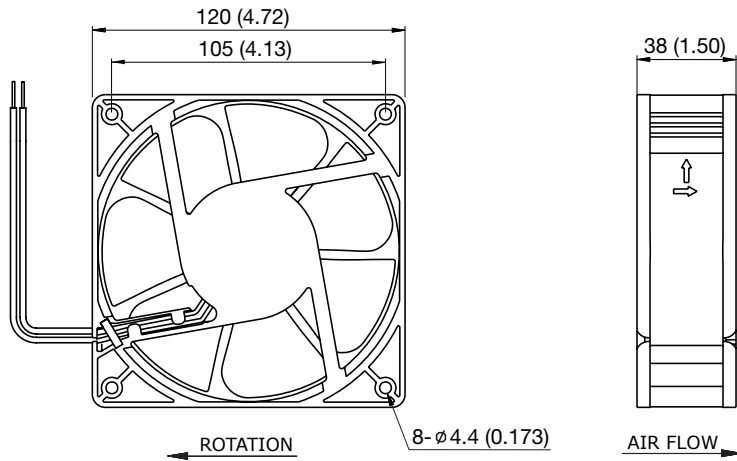

Air Performance

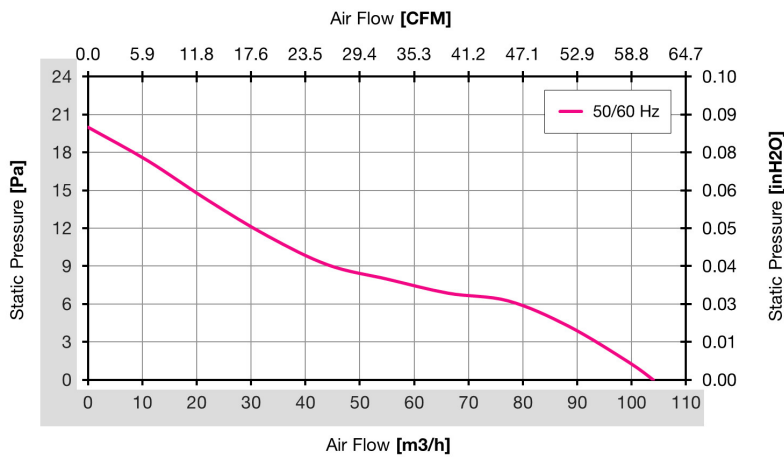

Image is for illustrative purpose only. All specifications, data and drawing are subject to change without notice. Please refer to our terms of sales including our warranty and limited liabilities clauses.